

## FEATURES

- Forged brass manifold with exclusive lifetime warranty
- New, over-sized connecting rods for ultimate crankcase performance
- Die cast, anodized aluminum, oil-bath crankcase
- Solid ceramic plungers with continuously lubricated packings
- The original Interpump unitized, stainless steel, K123 inlet and outlet valves
- Ideal for all general cleaning applications
- Comes standard with either SAE J609 gasoline engine mounting flange, or NEMA 56C mounting flange.\*
- Also available in "L" left-handed versions

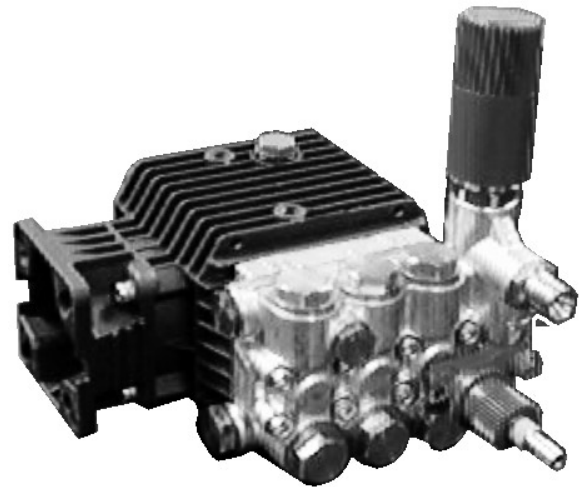

## SPECIFICATIONS

Pump Model	TP2520J34UIL	TP2526J34UIL	TP2530J34UIL	TP2533J34UIL
Maximum Volume	1.9 GPM	2.6 GPM	2.88 GPM	3.3 GPM
Maximum Discharge Pressure	2500 PSI			
Rated Pump Speed	3400 RPM			
Maximum Inlet Pressure	125 PSI			
Maximum Inlet Vacuum	3 ft. water (2.6 in. Hg)			
Bore	.591 in. / 15 mm			
Stroke (in. / mm)	.197 / 5	.260 / 6.6	.283 / 7.2	.315 / 8
Crankcase Oil Capacity	11.0 oz.			
Maximum Fluid Temperature	165°F			
Pump Inlet Port Thread	3/8-19 BSPP-F			
Unloader Inlet Port Thread	1/2-14 BSPP-F**			
Pump Discharge Port Thread	1/4-19 BSPP-F			
Unloader Discharge Port Thread	3/8-19 BSPP-M			
Hollow Shaft I.D.	3/4 in. / 19 mm			
Weight	11.4 lbs.			
Dimensions	7.0 x 7.2 x 5.5 in.			

**\*\*DO NOT use NPT Inlet Fitting; GP 680006 Inlet Fitting is recommended.**

## DIMENSIONAL DRAWING

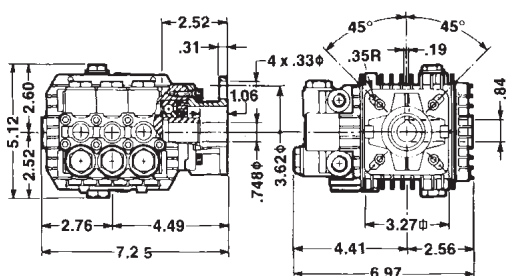

J34 Version

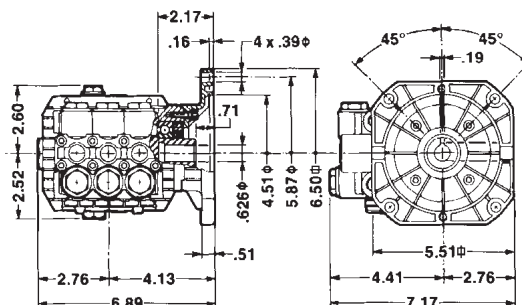

X34 Version

**NOTE:**  
Overall height  
w/unloader=8"



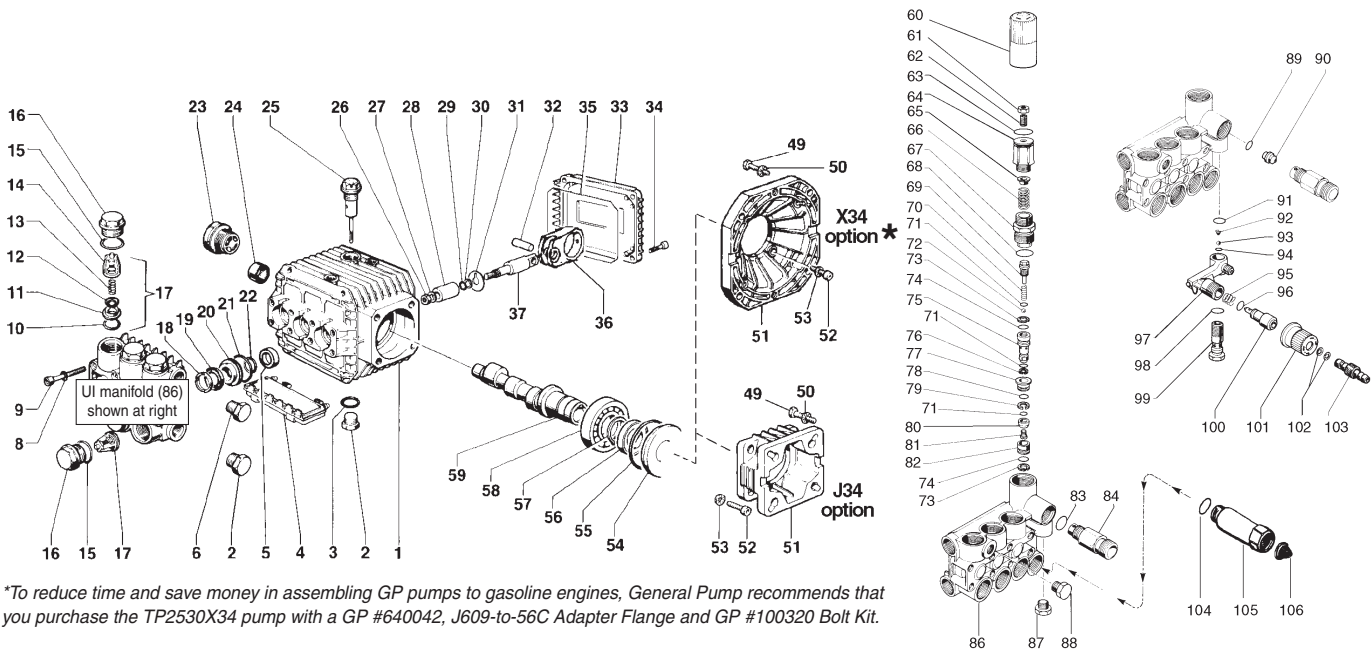

\*To reduce time and save money in assembling GP pumps to gasoline engines, General Pump recommends that you purchase the TP2530X34 pump with a GP #640042, J609-to-56C Adapter Flange and GP #100320 Bolt Kit.

### PARTS LIST

ITEM	PART NO.	DESCRIPTION	KIT NO.	QTY.	ITEM	PART NO.	DESCRIPTION	KIT NO.	QTY.	ITEM	PART NO.	DESCRIPTION	KIT NO.	QTY.
1.	51.0106.22	Crankcase		1	37.	51.0500.56	Plunger Rod		3	77.	36.3165.70	Valve Guide	102	1
2.	98.2100.00	Plug, 3/8		1	49.	99.2730.00	Screw, J34		4	78.	90.3589.00	O-Ring	102	1
3.	90.3833.00	O-Ring		1		99.3345.00	Screw, X34			79.	90.5075.00	Back-up Ring	102	1
4.	51.2091.02	Protector		1	50.	96.7014.00	Washer, J34		4	80.	36.3190.66	Valve	102	1
5.	90.1565.00	Oil Seal	83	3	51.	96.7104.00	Washer, X34			81.	99.1509.00	Screw	102	1
6.	98.2041.00	Plug, 1/4		1		10.0346.22	Flange, J34		1	82.	36.3164.66	Valve Seat	102	1
8.	96.6938.00	Washer		8		10.0344.22	Flange, X34			83.	90.3832.00	O-Ring	94	1
9.	99.1943.00	Screw		8	52.	99.1867.00	Screw		4	84.	10.0078.70	Nipple, 3/8 BSPP-M		1
10.	90.3841.00	O-Ring	123	6	53.	96.6938.00	Washer		4		10.0147.70	Nipple, M22-M		optional
11.	36.2003.66	Valve Seat	123	6	54.	50.2115.51	Spacer		1		10.0318.70	Nipple, 3/8 NPT-F		optional
12.	36.2001.76	Valve Plate	123	6	55.	90.4097.00	O-Ring		1	86.	51.1201.41	UI Manifold		1
13.	94.7376.00	Spring	123	6	56.	90.1644.00	Oil Seal		1	87.	98.2057.00	Cap		1
14.	36.2025.51	Valve Cage	123	6	57.	90.0667.00	Snap Ring		1	88.	98.2041.00	Cap		1
15.	90.3847.00	O-Ring		6	58.	20.2835.21	Bearing		1	89.	90.3822.00	O-Ring	94	1
16.	98.2216.00	Valve Cap		6	59.	51.0210.65	Crankshaft, TP2520		1	90.	10.0151.66	2 mm Nozzle		1
17.	36.7115.01	Valve Assy.	123	6		51.0211.65	Crankshaft, TP2526		1	91.	90.3582.00	O-Ring	94	1
18.	51.1000.51	Head Ring	96,97	3		51.0221.65	Crankshaft, TP2530		1	92.	94.8217.00	Spring	94	1
19.	90.2620.00	Packing	96,97	3		51.0218.65	Crankshaft, TP2533		1	93.	97.4782.00	Ball	94	1
20.	51.0800.70	Packing Retainer	86,96	3	60.	36.3187.51	Knob		1	94.	90.3572.00	O-Ring	94	1
21.	90.3604.00	O-Ring	86,96,97	3	61.	99.3068.00	Bolt, M8 x 25		1	95.	94.7383.00	Spring	94	1
22.	90.3835.00	O-Ring	86,96,97	3	62.	92.2223.00	Nut, M8		1	96.	90.3580.00	O-Ring	94	1
23.	97.5968.00	Sight Gauge		1	63.	90.3598.00	O-Ring, 20.35x1.78		1	97.	36.3181.51	Body		1
24.	20.2128.35	Needle Bearing		1	64.	36.3185.70	Pressure Regulator		1	98.	90.3585.00	O-Ring	94	1
25.	98.2103.00	Oil Dip Stick		1	65.	36.3169.70	Seat		1	99.	36.2563.70	Valve Seat		1
26.	92.2216.00	Nut		3	66.	94.7436.00	Spring, 15 x 36		1	100.	36.2564.70	Shuttle		1
27.	96.7008.00	Washer		3	67.	36.3184.70	Bushing	102	1	101.	36.2565.51	Knob		1
28.	51.0400.09	Plunger (15 mm)		3	68.	90.3847.00	O-Ring	102	1	102.	90.3570.00	O-Ring	94	2
29.	90.3572.00	O-Ring		3	69.	36.3188.70	Stopper	102	1	103.	36.2566.70	Coupling		1
30.	90.5022.00	Back Up Ring		3	70.	94.7332.00	Spring	102	1					
31.	96.7070.00	Finger Washer		3	71.	90.3575.00	O-Ring	102	3					
32.	97.7310.00	Conn. Rod Pin		3	72.	97.4800.00	Ball	102	1					
33.	51.1600.22	Crankcase Cover		1	73.	90.5065.00	Back-up Ring	102	2					
34.	99.1867.00	Screw		4	74.	90.3822.00	O-Ring	102	2					
35.	90.3917.00	Cover O-Ring		1	75.	36.3189.70	Piston	102	1					
36.	51.0301.22	Connecting Rod		3	76.	90.5025.00	Back-up Ring	102	1					

### REPAIR KITS

KIT NO.	83	86	94	96	97	102	123
ITEM NO.s INCLUDED IN KIT	5	20, 21, 22	83, 89, 91, 92, 93, 94, 95, 96, 98, 102	18, 19, 20, 21, 22	18, 19, 21, 22	67, 68, 69, 70, 71, 72, 73, 74, 75, 76, 77, 78, 79, 80, 81, 82	10, 11, 12, 13, 14, (17)
NUMBER OF ASSEMBLIES IN KIT	3	3	—	1	3	—	6
NUMBER OF CYLINDERS KIT WILL SERVICE	3	3	—	1	3	—	3

### TORQUE SPECS\*

Position	Ft.-lbs.
2	29.4
6	14.7
9	8.8
16	60.0
23	13.2
26	11.0
34	7.3
49	14.7
52	7.3

\*Decrease torque by 20% if threads are lubricated.

